The following page(s) are extracted from multi-page Kuhnke product catalogues or CDRoms and any page number shown is relevant to the original document. The PDF sheets here may have been combined to provide technical information about the specific product(s) you have selected.

Hard copy product catalogues, and CDRoms have been published describing Kuhnke Pneumatics, Solenoids, Relays and Electronics; some divided into different books. A list of current publications is available on this web site or from our sales offices. Some may be available for download, but as substantially larger files.

Contact Details

Kuhnke sales and service in the UK

H. Kuhnke Ltd
Unit 6 Focus 303
Focus Way, Walworth Business Park
Andover
Hampshire
SP10 5NY
United Kingdom

Tel: +44 (0)1264 364194
Fax: +44 (0)1264 365991
Email: sales@kuhnke.co.uk

Important Note

The information shown in these documents is for guidance only. No liability is accepted for any errors or omissions. The designer or user is solely responsible for the safe and proper application of the parts, assemblies or equipment described.

Timing using Start-Stop Pushbuttons

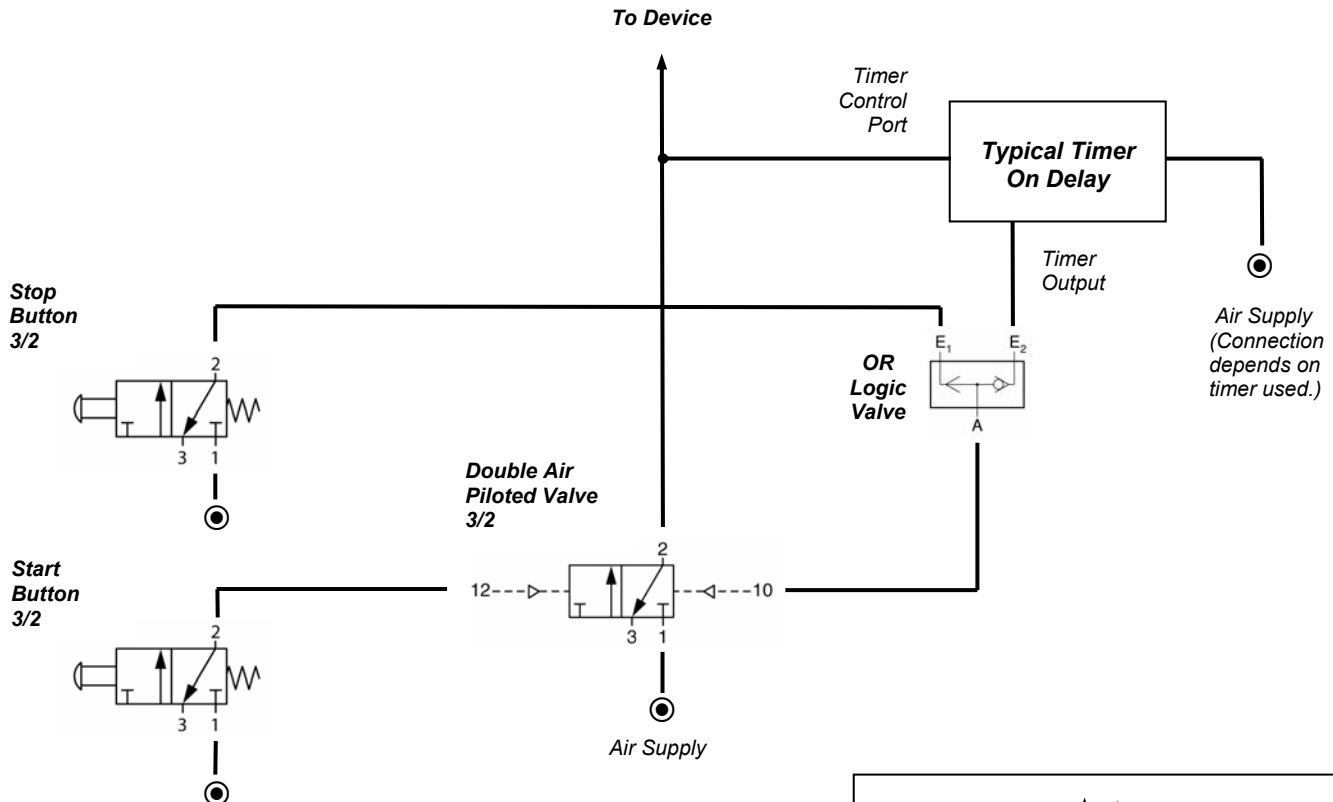

Separate start-stop pushbuttons can be used in conjunction with a double air piloted valve and an “or” logic valve to control a timing circuit if required. A wide selection of types and colours of pushbuttons is available to meet design requirements. The size of the air piloted valve determines the air volume output.

Operation

Pressing the start pushbutton sends a signal to switch the air piloted valve on. The valve output is connected to the device to be controlled and to the timer control port. When the timer reaches its set time it sends a signal back to the air pilot valve resetting it, turning off the output to the device. To stop the timing (ie. emergency stop) press the stop button, which sends a signal via the “or” logic valve to reset the double air piloted valve.

Typical Item Selection

Any on delay timer (consider length of time required and mounting preference).

Pushbutton 3/2 (choice of colour)- Cat. nos. 76022-62-21 (Red), -23 (Black) or -24 (Green).

Double air piloted valve 3/2- Cat. no. 76022-71-22 (1/8 Ports).

For larger sizes of double air piloted valves use a 5/2 valve and plug port 2 for 3/2 operation. Connect device and timer control to port 4 of 5/2 valve. Use Cat. nos. 76047-81-42 for 1/4 ports or 76067-81-42 for 1/2 ports.

Logic valve-“OR” cat. no. 47003.

